

1400-G-9

Door Thickness, Panel Layout, and Grain Patterns

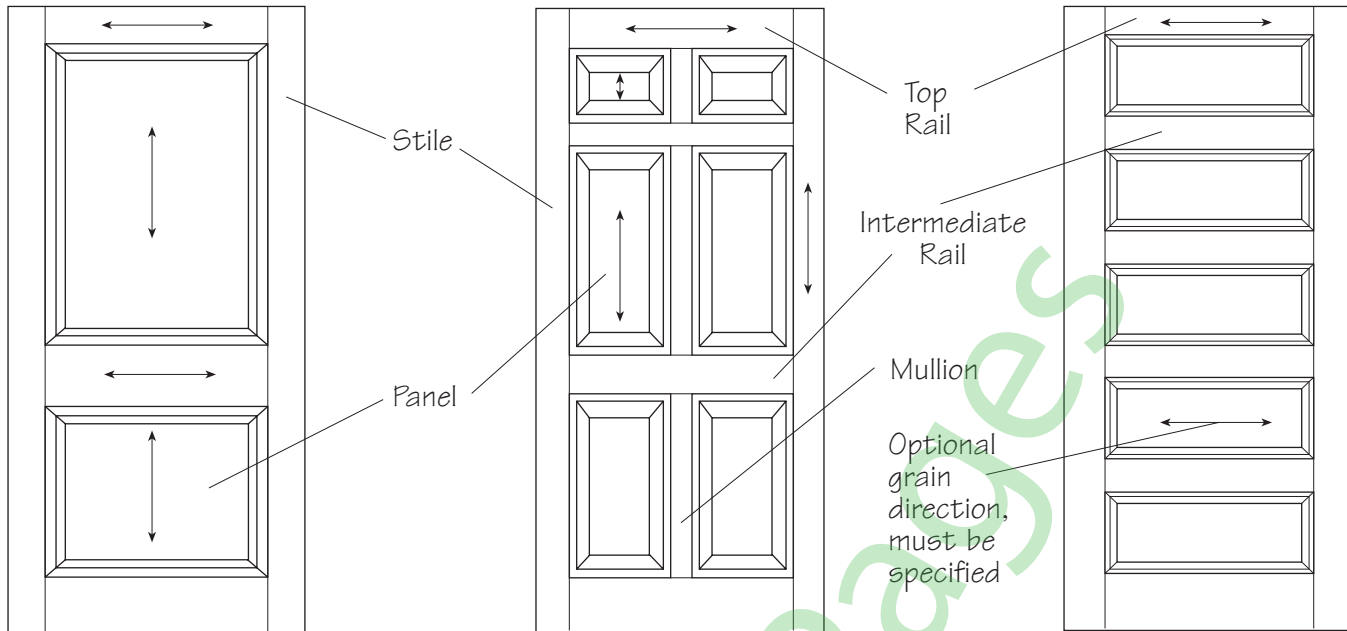

Layout and Grain - Figure 1400-03

Stile and rail doors are usually 44 mm [1-3/4"] thick. For doors over 1067 mm [3'-6"] in width or 2440 mm [8'-0"] in height, 57 mm [2-1/4"] minimum thickness is required. Doors over maximum width or height and required by specification to be less than 57 mm [2-1/4"] in thickness shall not be subject to this Standard's test for warp. Traditionally, the grain direction flows with the longest dimension of the stile, rail, or panel. Panel grain direction can sometimes be altered for design purposes, and must be specified. If raised panels are to be rim-raised veneered construction, the grain of the rims will flow around the panel with the long dimension of the rim material.

1400-G-10

Stile and Rail Construction

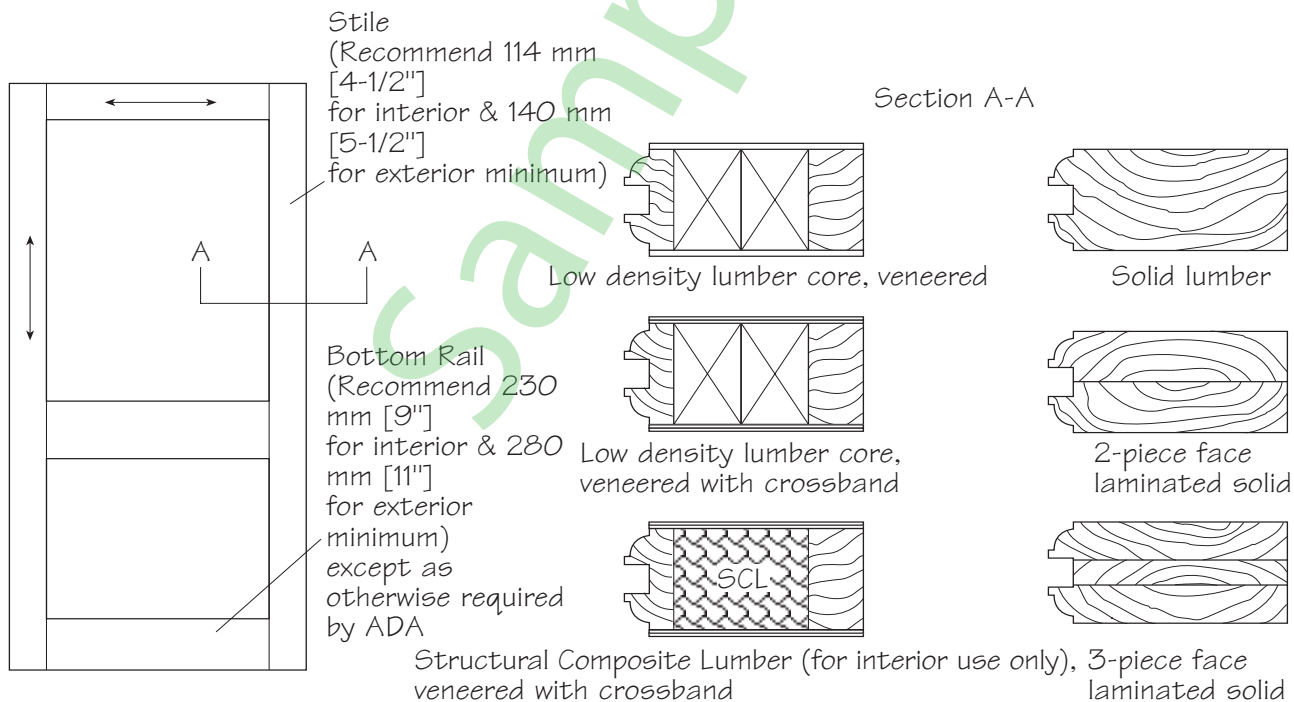

Stile and Rail Options - Figure 1400-04

There are a variety of methods of stile and rail fabrication. It is possible to fabricate stile and rail doors that will perform within the tests established in the Test Sections of this Standard using any of the illustrated techniques and others.

**1400-G-11**  
**Panel Construction**

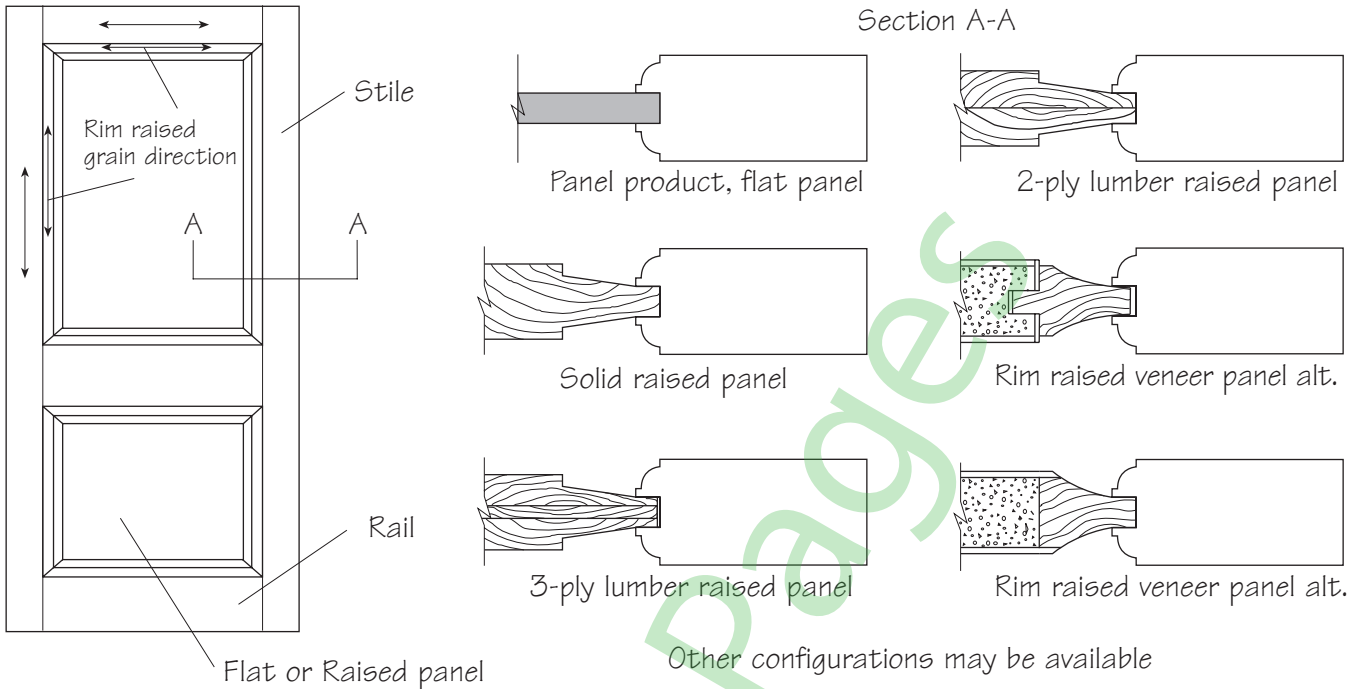

*Panel options - Figure 1400-05*

There are a variety of methods of flat panel and raised panel fabrication. Review the Standards in this section for maximum allowable widths in solid or edge-glued lumber. It is possible to fabricate stile and rail doors that will perform within the tests established in the compliance criteria of this standard using any of the illustrated techniques and others.

**1400-G-12**  
**Panel and Glass Retention**

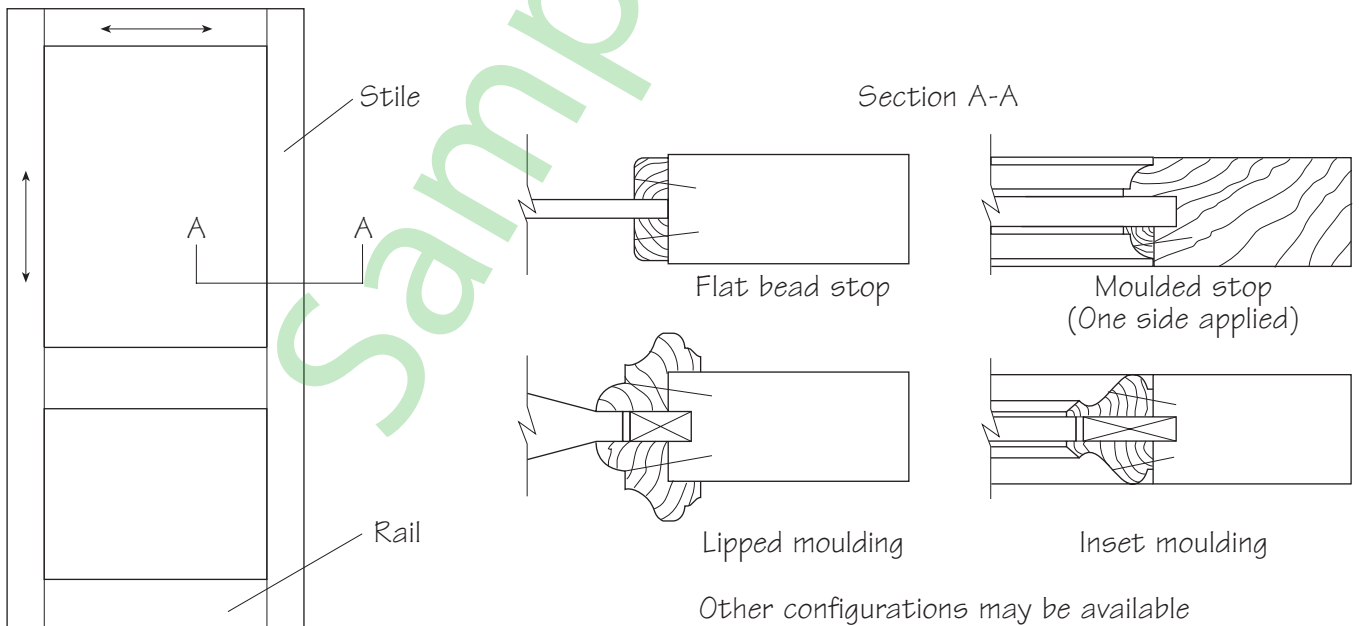

*Panel and Glass details - Figure 1400-06*

A wide variety of design choices are available from woodworkers. The illustrations are intended as guidelines for the design professional and should not limit the potential for creative solutions. Glass cannot always be centered on stiles and rails, depending on the thickness. Mouldings and stop are usually applied with small brads or finish nails.



## Technical Criteria

### 1400-T-1

#### Specification Requirements

Specific requirements for face, matching veneers, vertical edges, lights, louvers, moulding and transoms are provided in the following tables. Grade must be specified.

Architect or Design Professional shall ...

- specify the Grade required;
- specify the species and type of cut, if other than plain sawn;
- specify whether the panels are to be flat, rim-raised or solid;
- specify the ornamental details and joinery which affect the aesthetics and function;
- specify the preservative treatment for exterior use, if required
- specify the fire retardant rating, if required; and
- specify the fabrication techniques or door types as appropriate.

### 1400-T-2

#### Face Material Requirements

##### Veneers for Transparent Finishes

###### Premium Grade

“AA” grade faces are required for Premium Grade doors. Veneer is required to be of sufficient thickness to preclude sand-through, show-through of core, and glue bleed.

###### Custom Grade

“A” grade faces are required for Custom Grade doors. Veneer is required to be of sufficient thickness to preclude sand-through, show-through of core, and glue bleed.

###### Economy Grade

“B” grade faces are required for Economy Grade doors. Veneer is required to be of sufficient thickness to preclude sand-through, show-through of core, and glue bleed.

##### Solid Lumber for Transparent Finish

###### Premium Grade

Grade I hardwood or softwood

###### Custom Grade

Grade II hardwood or softwood

###### Economy Grade

Manufacturer’s option

## Materials for Opaque Finishes

### Premium Grade

Grade II hardwood or Grade I softwood lumber or sound close grain hardwood veneer, minimum “A” grade. Plain medium density fiberboard (MDF) or medium density overlay (MDO) also permitted.

### Custom Grade

Grade II lumber or sound close grain hardwood veneer, minimum “B” grade. Plain medium density fiberboard (MDF) or medium density overlay (MDO) also permitted.

### Economy Grade

Mill option

### 1400-T-3

#### Core Requirements (for Veneered Fabrication)

The architect/specifier is required to make a core selection depending upon the application. In some cases medium density fiberboard (MDF) core is recommended for panels. Stave lumber core is the traditional core for stile and rails. SCLC may be used for any Grade stiles or rails. MDF maybe used for stiles or rails when specified or approved by the design professional in Premium Grade. The core materials are manufactured according to the following:

##### Medium Density Fiberboard Core (MDF)

Medium Density Fiberboard (MDF) core is manufactured to the ANSI standard A208.2.

##### Structural Composite Lumber Core (SCLC)

An engineered composite that utilizes wood strands from a variety of tree species providing an alternative to dimension lumber. The material is engineered for strength and stability. While not really “lumber,” it is marketed as a lumber substitute, to be used in primarily place of stave lumber core materials. SCLC is tested under a number of ASTM and other test criteria. There are insufficient data to recommend SCLC for exterior use.

##### Low Density (Stave) Lumber Core

May be a combination of blocks or strips, not more than 63.5 mm [2-1/2"] wide, of one species of wood at 6 to 9 percent moisture content. Joints to be tight and staggered in adjacent rows.

**1400-T-4**

**Exposed Vertical Edges**

**Premium Grade**

Same species as face, lumber, or veneer over hardwood.  
Joints not allowed. Sanded ease.

**Custom Grade**

Same species as face, lumber, or veneer, or compatible hardwood. Joints allowed. Sanded ease.

**Economy Grade**

Manufacturer's option

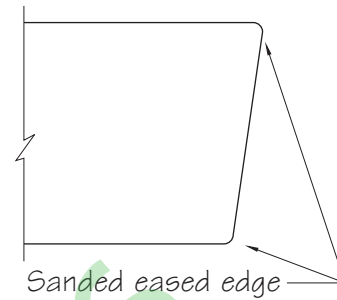

**1400-T-5**

**Glass and Glazing**

In the absence of specifications, the following standards will apply. Where more than one method or material is listed for a Grade, woodworkers will supply their choice from the alternatives.

Glass/Glazing	Premium	Custom	Economy
Wood Moulding Glass Stop	Plant prepared and bundled in sets appropriately labeled for the jobsite	Plant prepared and bundled in sets appropriately labeled for the jobsite	Shipped loose without preparation
Type, thickness, and manufacturer of glass, particularly insulated glass, must be specified as its construction dictates details of the receiving members. Specifications regarding code compliance are the responsibility of the design professional.			
In the absence of specifications, profile of stop shall be mill option.			
<b>It is recommended that the following be included in the painting section of the specifications: "To create the proper seal against weather, wind, and rain, the finish coats of all doors should be allowed to flow onto the glass area at least 1.6 mm [1/16"]. When cleaning the glass, a razor blade should not be used to scrape the glass. This will destroy the seal. A broad blade putty knife should be used to protect the seal between the glass and the wood."</b>			

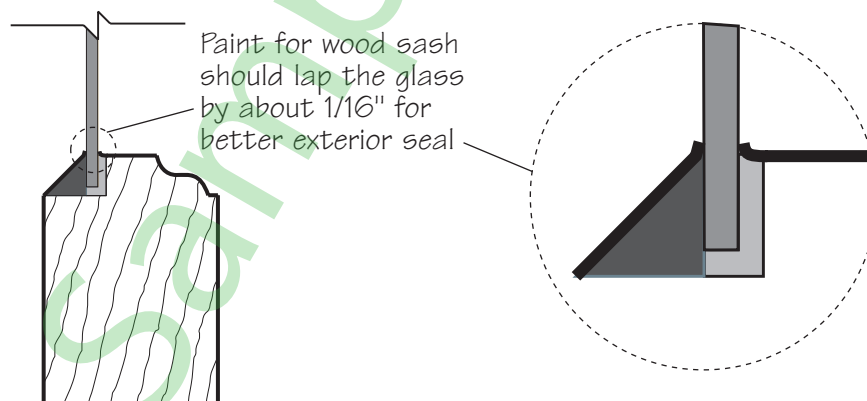

Flow paint seal - Figure 1400-07