

MATERIAL NOTES

THE FOLLOWING ENGINEERING DRAWINGS ILLUSTRATE THE TESTED ENGINEERING OF DOWELED CONSTRUCTION WALL CABINETS USING GRADE 130 MDF, M-2 PARTICLEBOARD, AND VENEER CORE PLYWOOD. THESE DRAWINGS DO NOT INDICATE COMPLIANCE WITH AWI STANDARD. MANUFACTURERS SHALL ACQUIRE AN OFFICIAL AWI TEST REPORT IN ORDER TO INDICATE COMPLIANCE.

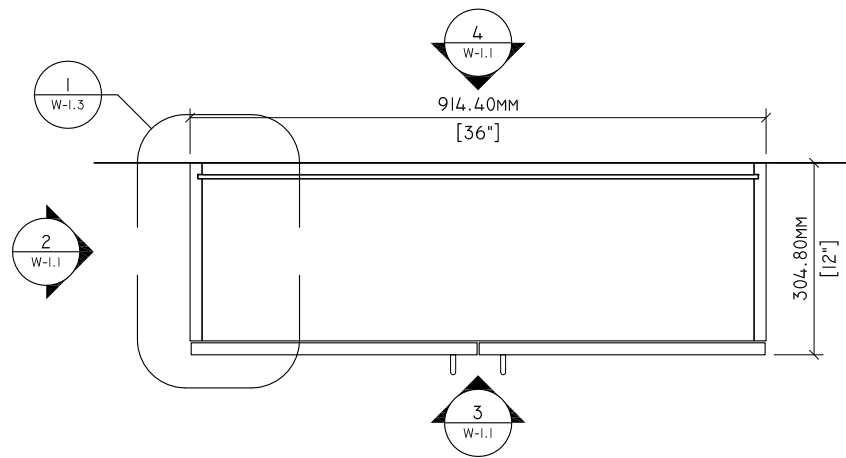

1 PLAN
W-1.1 1" = 1'-0"

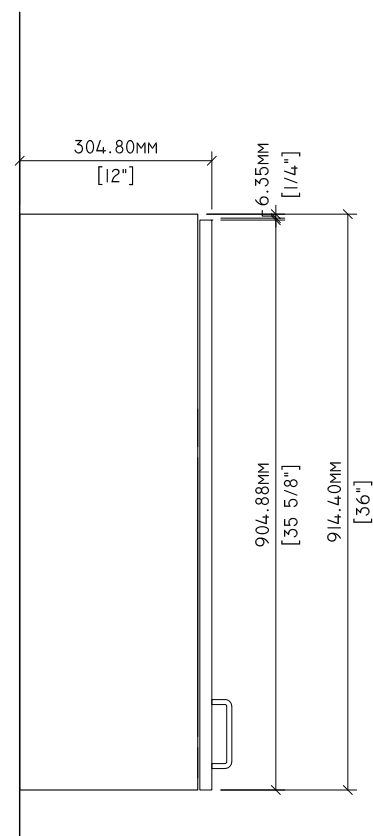

2 SIDE ELEVATION
W-1.1 1" = 1'-0"

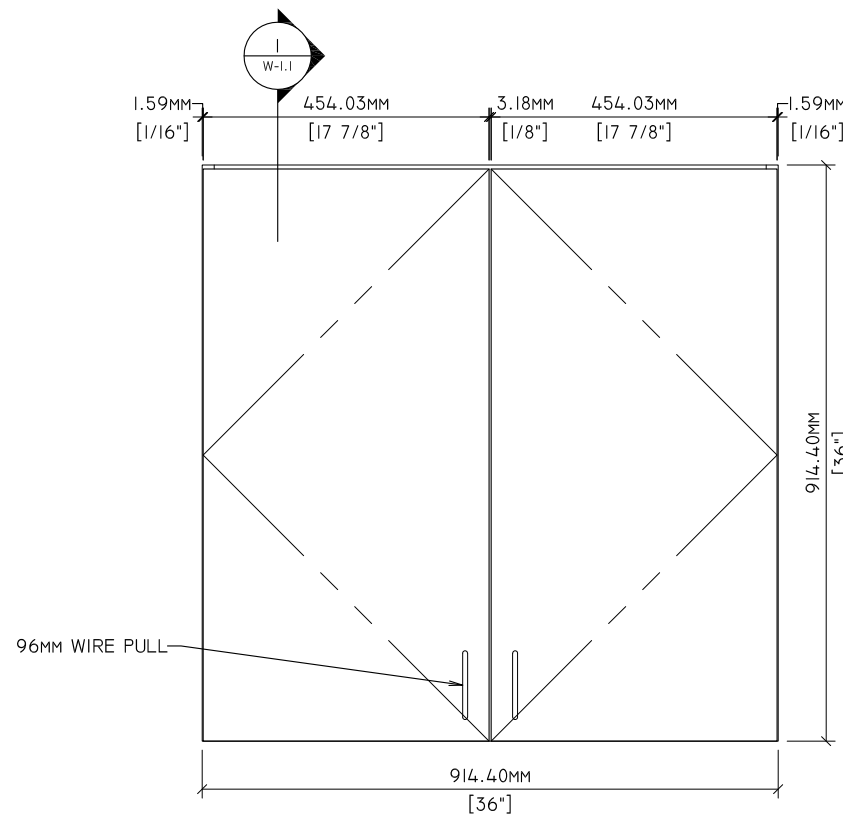

3 ELEVATION
W-1.1 1" = 1'-0"

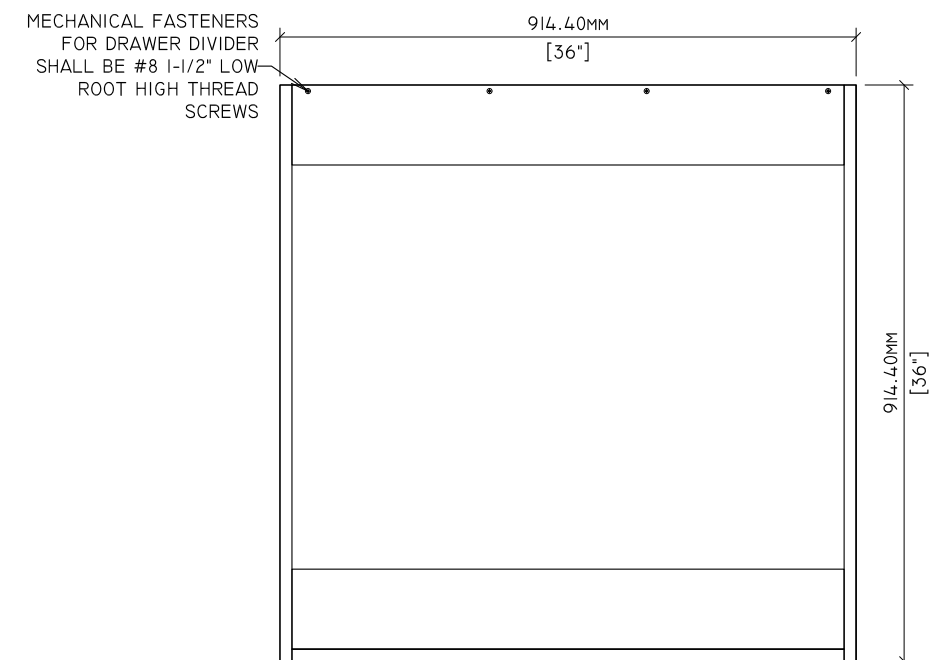

4 BACK ELEVATION
W-1.1 1" = 1'-0"

MECHANICAL FASTENERS FOR DRAWER DIVIDER SHALL BE #8 1-1/2" LOW ROOT HIGH THREAD SCREWS

| Drawn By: | | REVISIONS | | SPECIMEN DWG. NO.: |
|--------------|------|-----------|------------|--------------------------------|
| Drawn By: | HD | | | W-1.1 |
| Reviewed By: | - | △1 | - | JOINERY METHOD NO.: 8MM DOWEL |
| Revised By: | -HKM | △2 | - 7/7/2020 | SPECIMEN MATERIAL: MDF, PB, VC |
| Revised By: | - | △3 | - | BATCH QUANTITY: - |
| Approved By: | - | △4 | - | SCALE: AS NOTED |

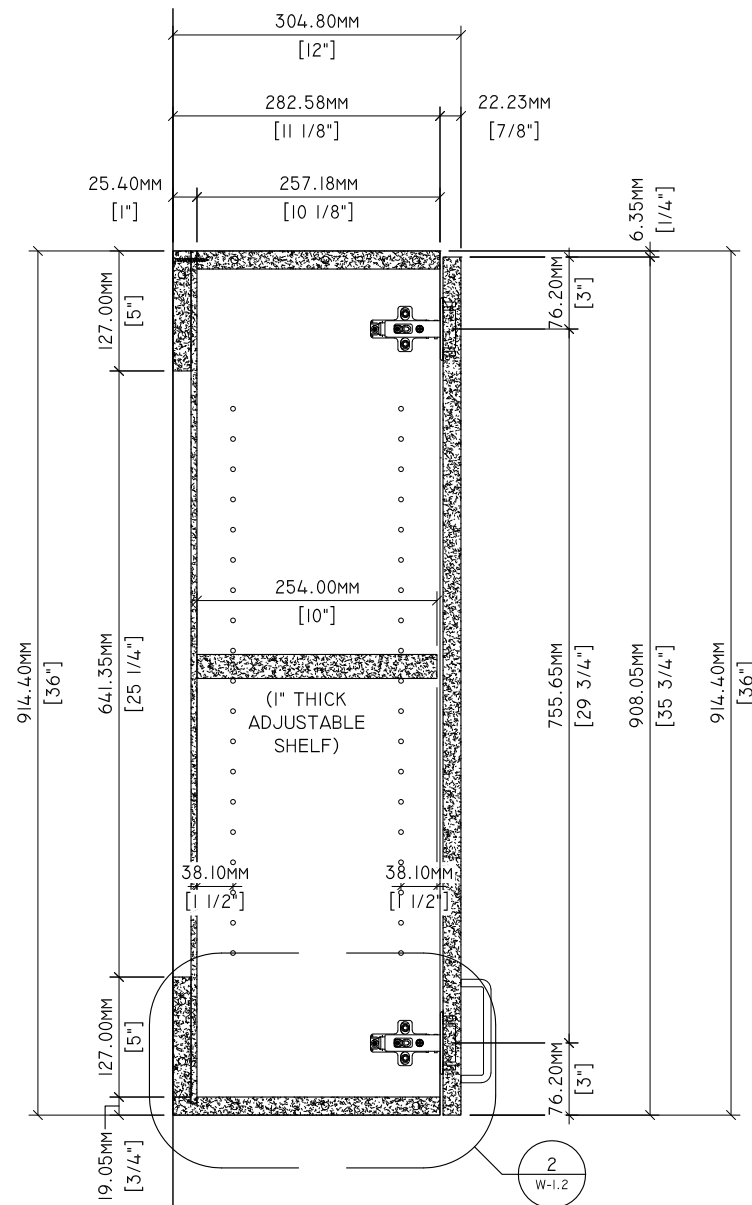

1 SECTION
W-1.2 1-1/2" = 1'-0"

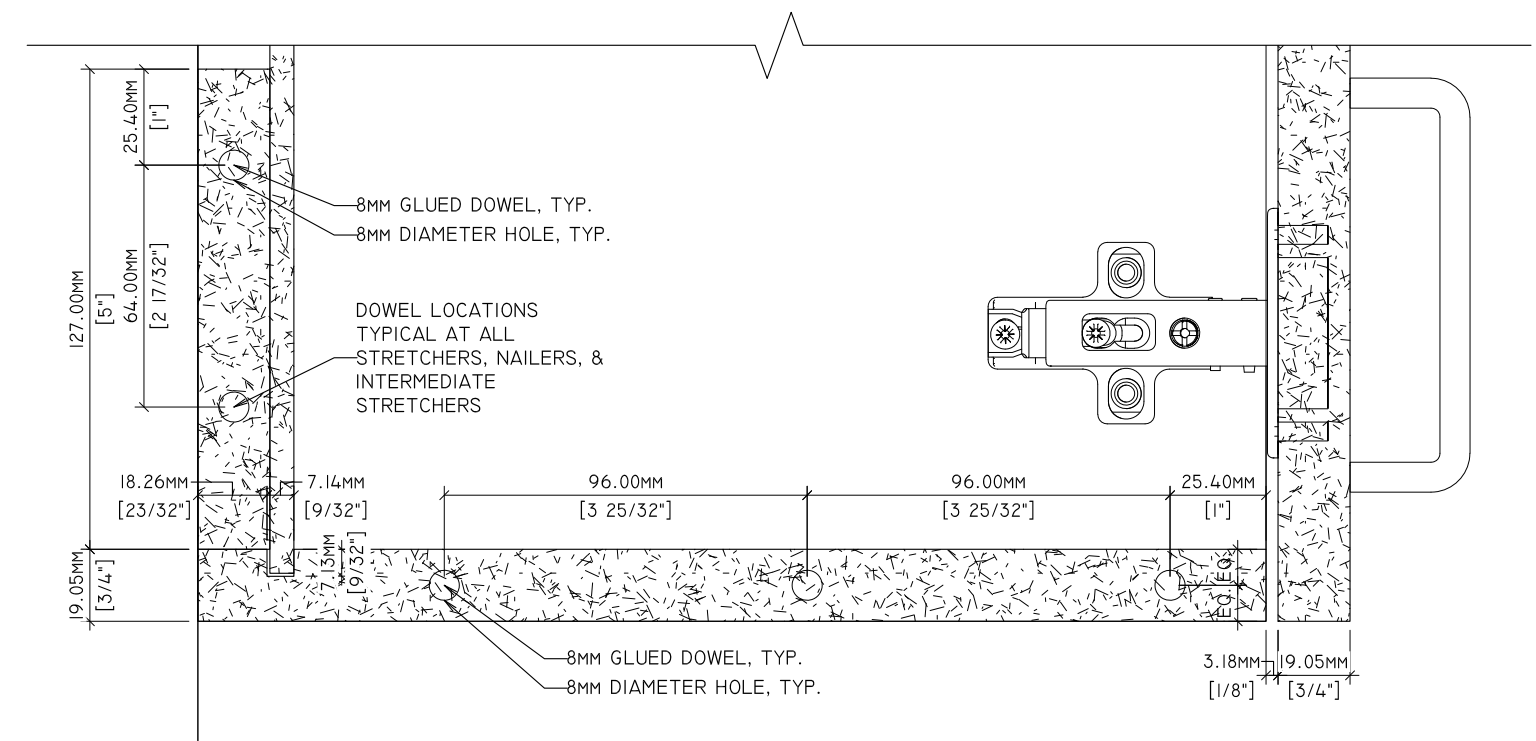

2 DETAIL
W-1.2 6" = 1'-0"



Standards Development and Performance Testing
1310 Southerfield Road
Americus, GA 31709

| | | | | |
|--------------|-----|------------------|------------|--------------------------------|
| Drawn By: | HD | REVISIONS | | SPECIMEN DWG. NO.: W-1.2 |
| Reviewed By: | - | ① | - | JOINERY METHOD NO.: 8MM DOWEL |
| Revised By: | HKM | ② | - 7/7/2020 | SPECIMEN MATERIAL: MDF, PB, VC |
| Revised By: | - | ③ | - | BATCH QUANTITY: - |
| Approved By: | - | ④ | - | SCALE: AS NOTED |

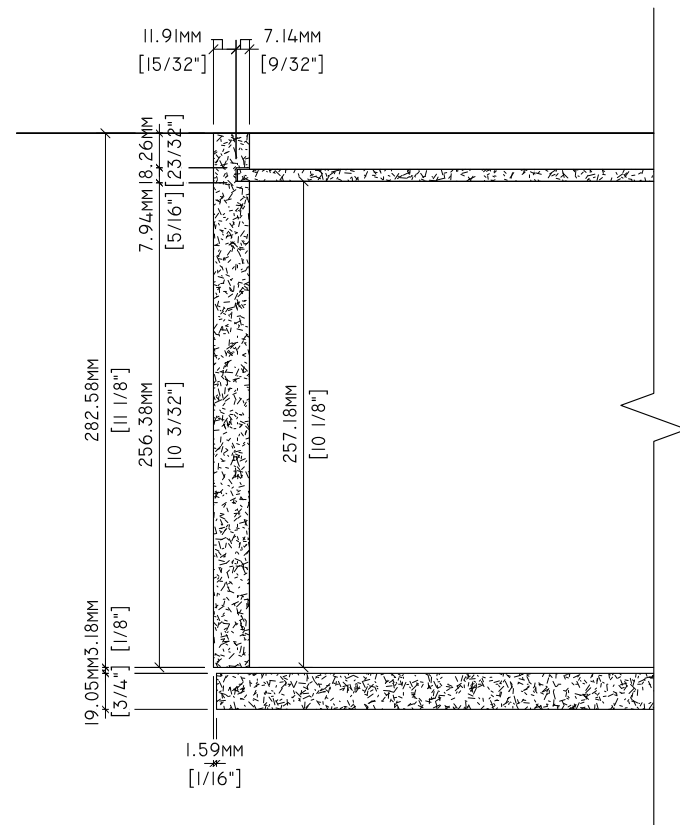

1 PLAN DETAIL
W-1.3 3" = 1'-0"

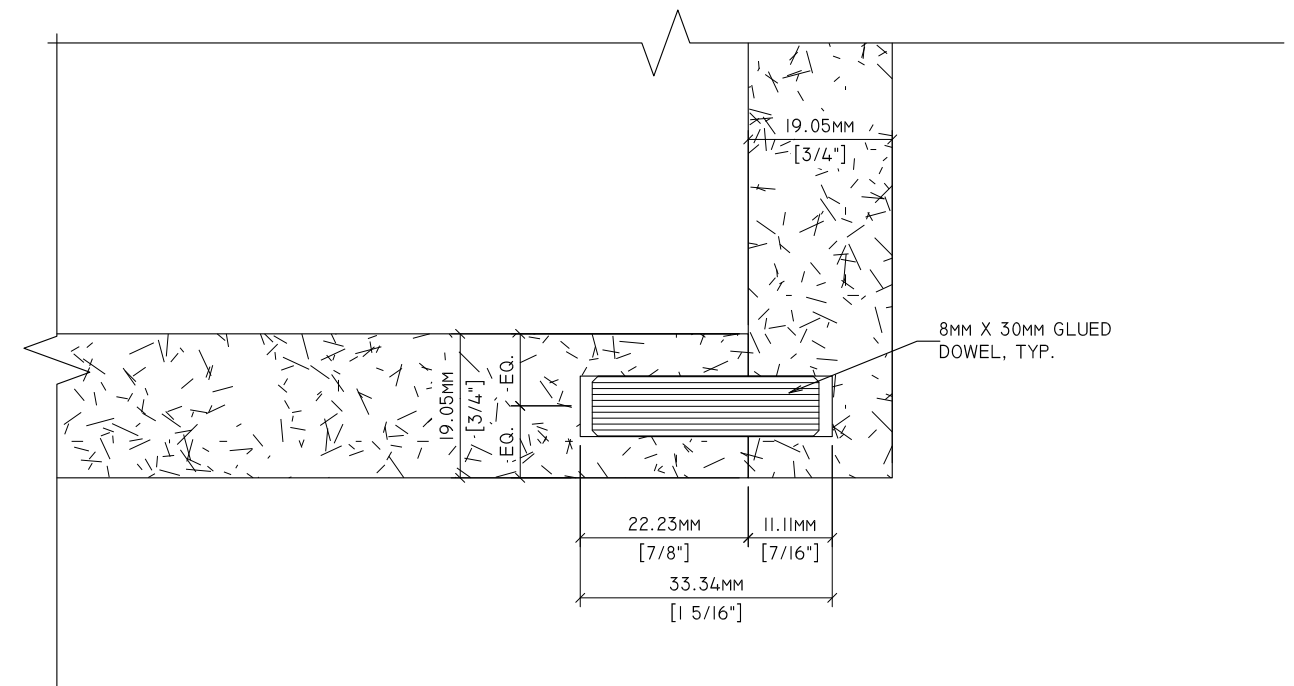

2 DETAIL
W-1.3 12" = 1'-0"

| | | | | |
|--------------|-----|------------------|------------|--------------------------------|
| Drawn By: | HD | REVISIONS | | SPECIMEN DWG. NO.: W-1.3 |
| Reviewed By: | - | △1 | - | JOINERY METHOD NO.: 8MM DOWEL |
| Revised By: | HKM | △2 | - 7/7/2020 | SPECIMEN MATERIAL: MDF, PB, VC |
| Revised By: | | △3 | - | BATCH QUANTITY: - |
| Approved By: | - | △4 | - | SCALE: AS NOTED |