

1 PLAN  
B-2.1 1" = 1'-0"

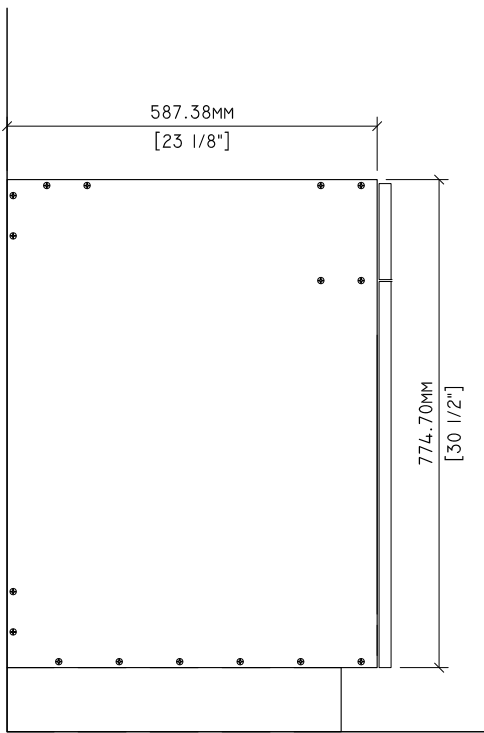

2 SIDE ELEVATION  
B-2.1 1" = 1'-0"

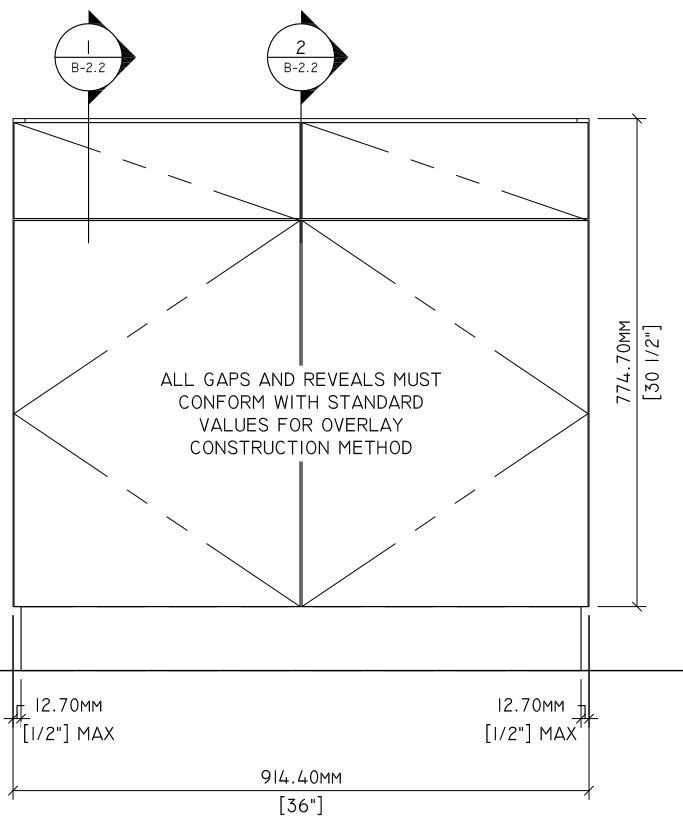

3 ELEVATION  
B-2.1 1" = 1'-0"

MECHANICAL FASTENERS FOR DRAWER DIVIDER SHALL BE 7MM X 50MM CONFIRMAT CONNECTORS

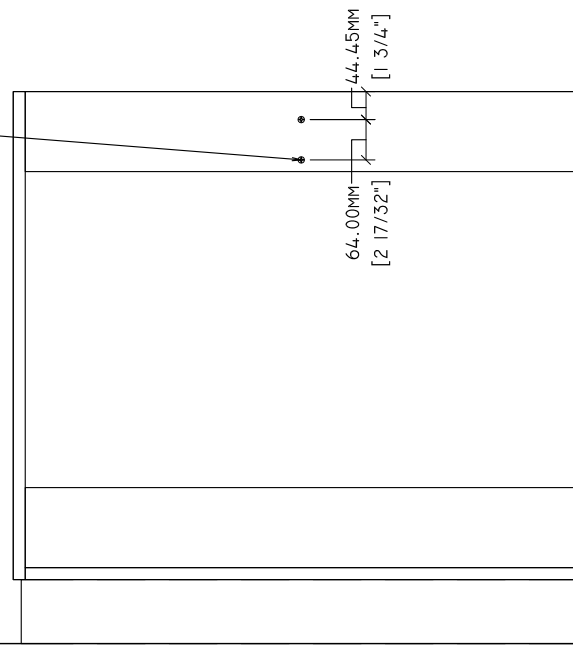

4 BACK ELEVATION  
B-2.1 1" = 1'-0"

### MATERIAL NOTES

ITEM	NOM. THICK	CORE MATERIAL	CORE GRADE	FACE MATERIAL	BACK MATERIAL
LEFT VERTICAL SIDE	3/4"	MDF	I30	TFL	TFL
RIGHT VERTICAL SIDE	3/4"	MDF	I30	TFL	TFL
TOP HORIZONTAL COMPONENT	3/4"	MDF	I30	TFL	TFL
BOTTOM HORIZONTAL COMPONENT	3/4"	MDF	I30	TFL	TFL
ADJUSTABLE SHELF	1"	MDF	I30	RAW	RAW
VERTICAL BACK COMPONENT	1/4"	MDF	I30	TFL	TFL
HINGED DOORS	3/4"	MDF	I30	TFL	TFL
DRAWER FRONTS	3/4"	MDF	I30	TFL	TFL
NAILER COMPONENT	3/4"	MDF	I30	TFL	TFL

### PERMISSIBLE TOLERANCES

- PERMISSIBLE TOLERANCES, PROVIDED ALL AESTHETIC STANDARD REQUIREMENTS ARE MET:
  - STRETCHERS AND NAILERS MAY ALLOW FOR A TOLERANCE OF +/- 1.6MM [1/16"] IN WIDTH
  - MACHINED JOINERY AND FASTENERS USED FOR STRUCTURAL PERFORMANCE MUST MAINTAIN SPACING PATTERN BASED ON TESTED PRODUCT AND ENGINEERING DRAWINGS
  - MACHINING +/- 1 MM [.039"], EXCLUDING DRILL DIAMETERS
  - ADDITIONAL FASTENERS AND/OR ADHESIVE MAY BE USED TO MEET AESTHETIC REQUIREMENTS

\*SUBJECT TO CHANGE WITHOUT NOTICE. LATEST EDITION WILL BE ENFORCED.

### GENERAL NOTES

- THESE DRAWINGS DO NOT INDICATE CONFORMANCE WITH AWI STANDARDS. MANUFACTURERS SHALL ACQUIRE AN OFFICIAL AWI TEST REPORT IN ORDER TO INDICATE CONFORMANCE.
- CABINET SIZE AND CONFIGURATION MAY BE ALTERED AS LONG AS JOINERY, SPACING, AND LOCATION REQUIREMENTS ARE FOLLOWED.
- ALL JOINERY SHALL MEET THE TOLERANCES OF AWI STANDARDS.
- DOWELS SHALL BE 8MM X 30MM.
- CONSTRUCTION ILLUSTRATED HEREIN IS CONFORMING FOR ALL FRAMELESS DOOR AND DRAWER OVERLAYS.



**Standards Development and Performance Testing**  
1310 Southerfield Road  
Americus, GA 31709

Drawn By:		REVISIONS		SPECIMEN DWG. NO.:
HD		1	-	B-2.1
Reviewed By:	-	2	7/7/2020	JOINERY METHOD NO.: 8MM DOWEL
Revised By:	HKM	3	7/9/2021	SPECIMEN MATERIAL: MDF 130
Revised By:	HKM	4	-	BATCH QUANTITY: -
Approved By:	-			SCALE: AS NOTED

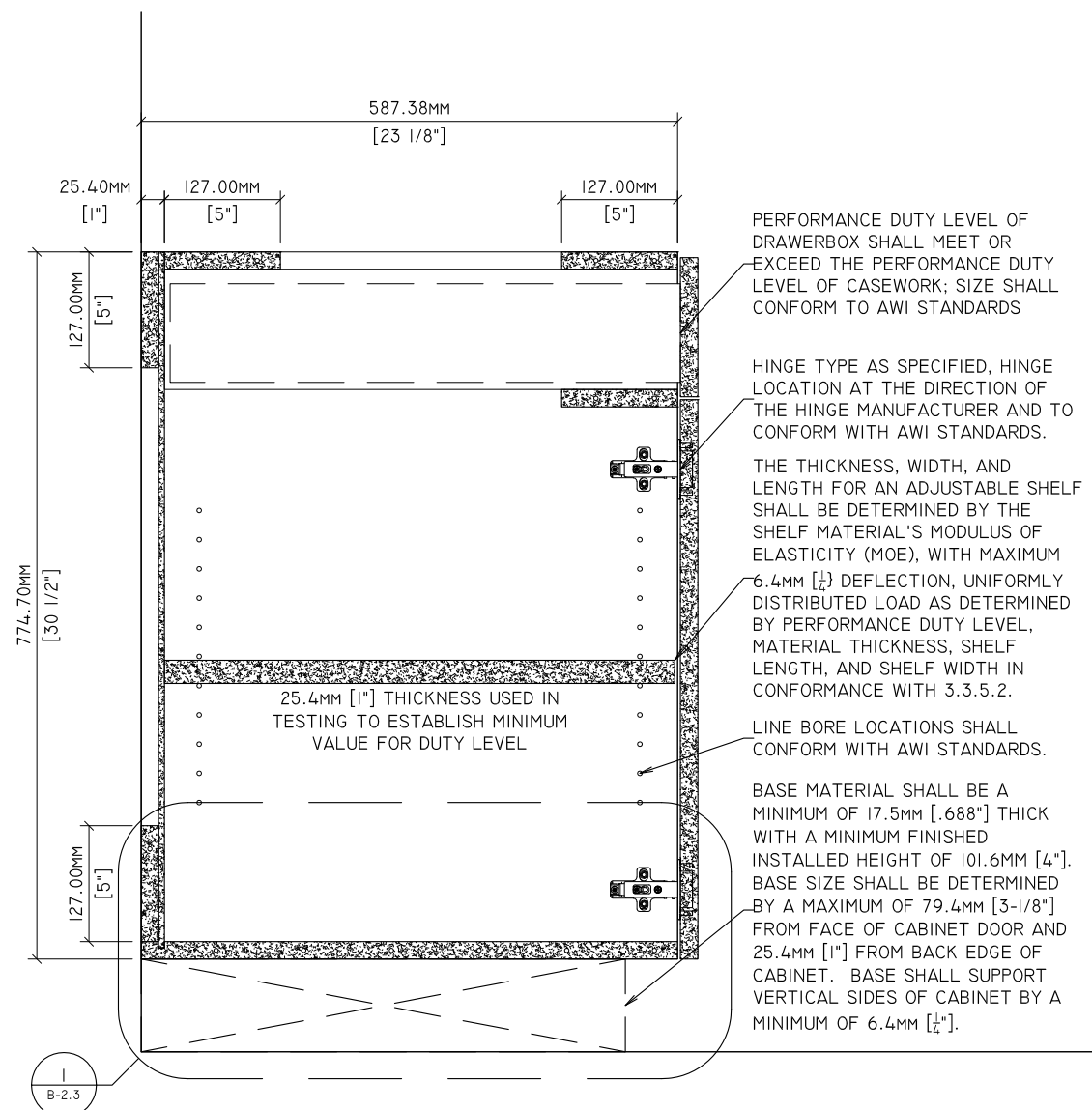

1 SECTION  
B-2.2 1-1/2" = 1'-0"

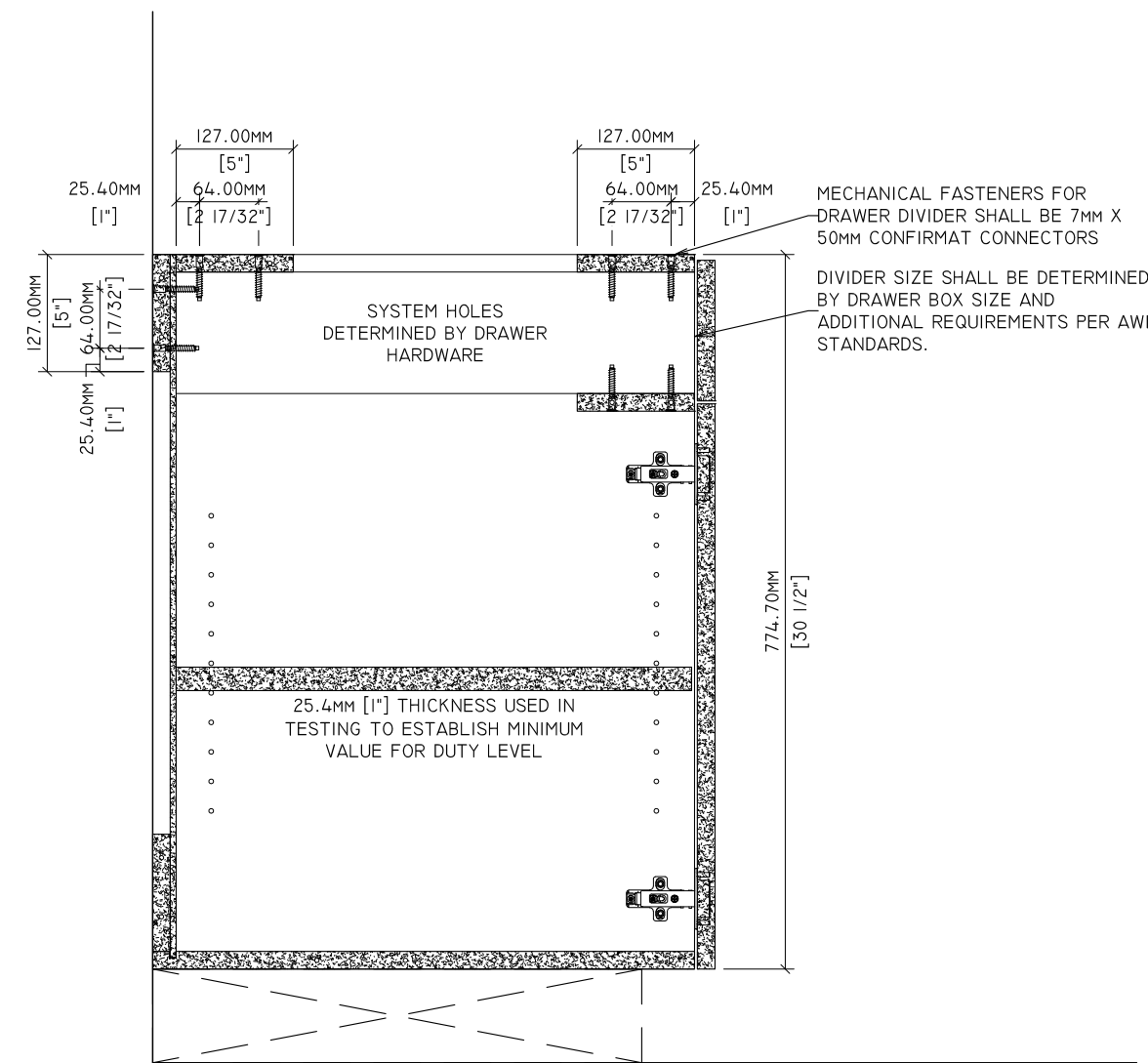

2 SECTION: DRAWER DIVIDER FASTENER LOCATIONS  
B-2.2 1-1/2" = 1'-0"

Drawn By:	HD	<b>REVISIONS</b>		SPECIMEN DWG. NO.: B-2.2
Reviewed By:	-	①	-	JOINERY METHOD NO.: 7mm X 50mm CONFIRMAT
Revised By:	HKM	②	7/7/2020	SPECIMEN MATERIAL: MDF 130
Revised By:	HKM	③	7/9/2021	BATCH QUANTITY: -
Approved By:	-	④	-	SCALE: AS NOTED

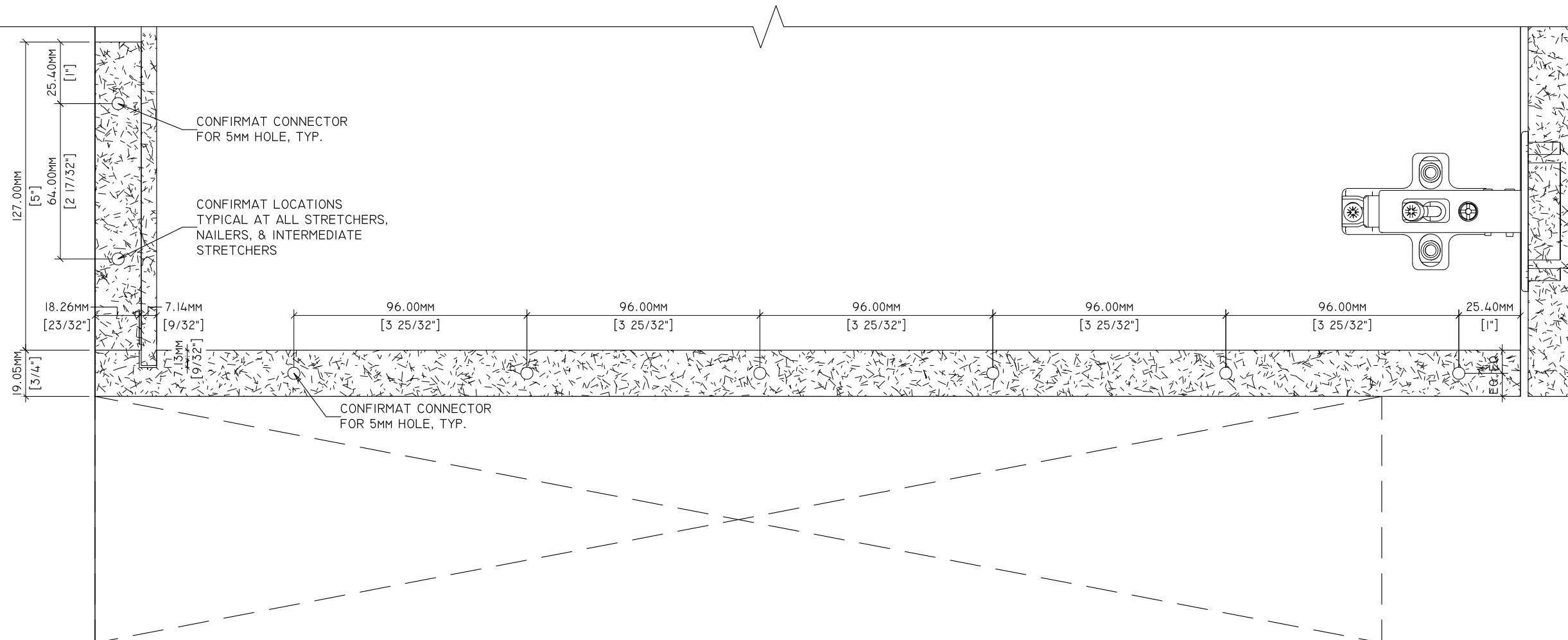

1 DETAIL  
B-2.3 6" = 1'-0"

Drawn By:	HD	<b>REVISIONS</b>		SPECIMEN DWG. NO.: B-2.3
Reviewed By:	-	①	-	JOINERY METHOD NO.: 7mm X 50mm CONFIRMAT
Revised By:	HKM	②	7/7/2020	SPECIMEN MATERIAL: MDF 130
Revised By:	HKM	③	7/9/2021	BATCH QUANTITY: -
Approved By:	-	④	-	SCALE: AS NOTED

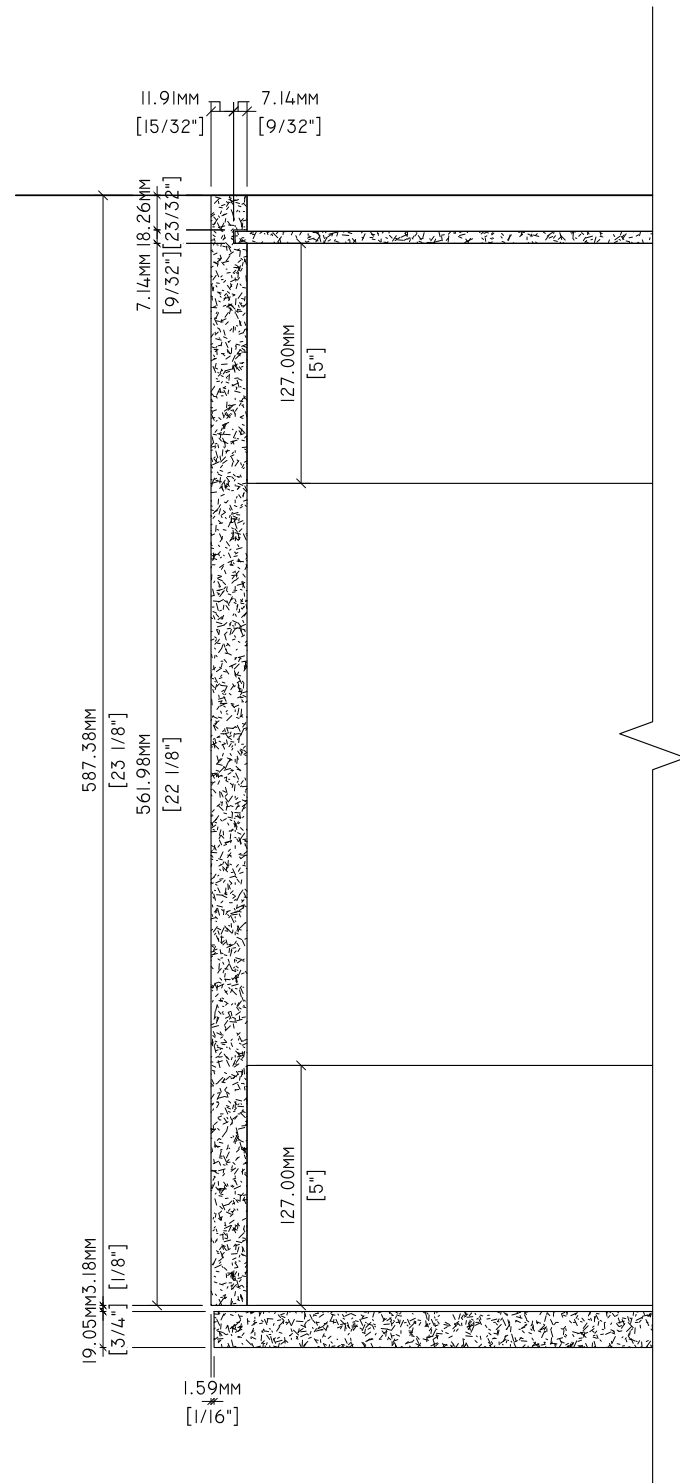

1 PLAN DETAIL  
B-2.4 3" = 1'-0"

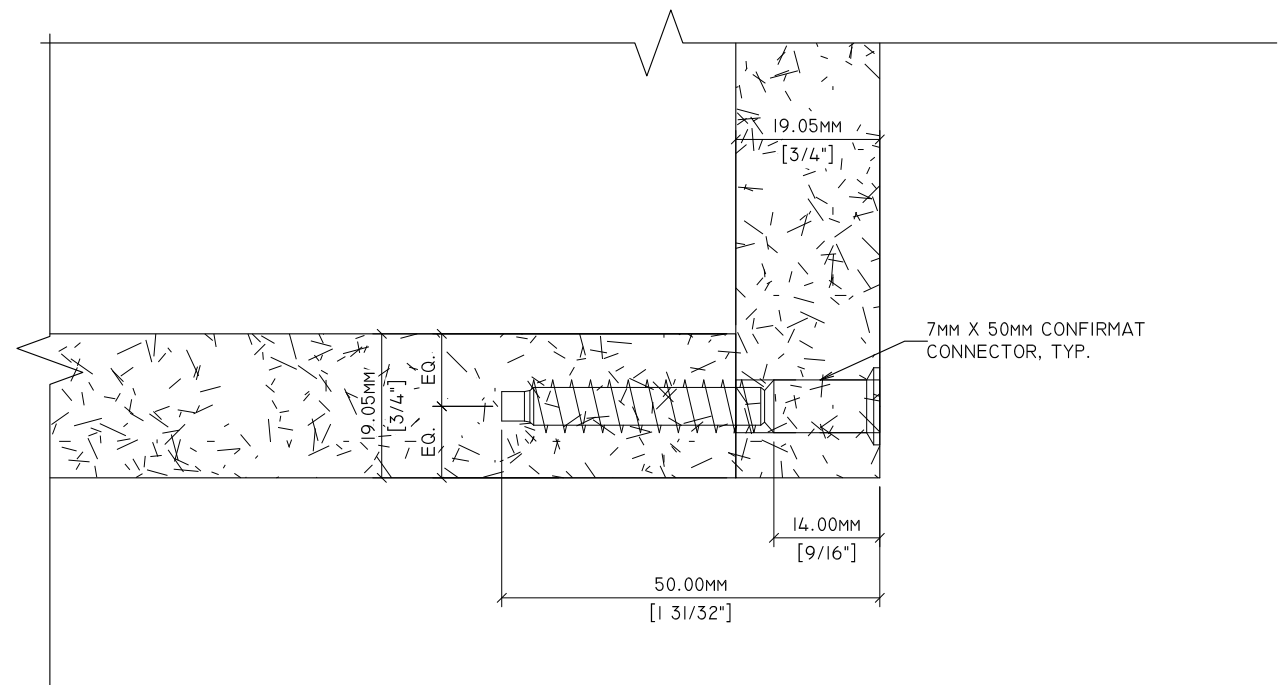

2 DETAIL  
B-2.4 12" = 1'-0"

Drawn By:	HD	<b>REVISIONS</b>		SPECIMEN DWG. NO.: B-2.4
Reviewed By:	-	①	-	JOINERY METHOD NO.: 7mm X 50mm CONFIRMAT
Revised By:	HKM	②	7/7/2020	SPECIMEN MATERIAL: MDF 130
Revised By:	HKM	③	7/9/2021	BATCH QUANTITY: -
Approved By:	-	④	-	SCALE: AS NOTED